

## Research on data system framework and key technologies of EV charging station maintenance

Liao, Jiaqi; Fang, Hualiang; Qian, Kejun; Zhou, Chengke; Dai, Luyang

*Published in:*  
IOP Conference Series: Earth and Environmental Science

*DOI:*  
[10.1088/1755-1315/342/1/012026](https://doi.org/10.1088/1755-1315/342/1/012026)

*Publication date:*  
2019

*Document Version*  
Publisher's PDF, also known as Version of record

[Link to publication in ResearchOnline](#)

*Citation for published version (Harvard):*  
Liao, J, Fang, H, Qian, K, Zhou, C & Dai, L 2019, 'Research on data system framework and key technologies of EV charging station maintenance', *IOP Conference Series: Earth and Environmental Science*, vol. 342, no. 1, 012026. <https://doi.org/10.1088/1755-1315/342/1/012026>

### General rights

Copyright and moral rights for the publications made accessible in the public portal are retained by the authors and/or other copyright owners and it is a condition of accessing publications that users recognise and abide by the legal requirements associated with these rights.

### Take down policy

If you believe that this document breaches copyright please view our takedown policy at <https://edshare.gcu.ac.uk/id/eprint/5179> for details of how to contact us.

PAPER • OPEN ACCESS

## Research on data system framework and key technologies of EV charging station maintenance

To cite this article: Jiaqi Liao *et al* 2019 *IOP Conf. Ser.: Earth Environ. Sci.* **342** 012026

View the [article online](#) for updates and enhancements.

You may also like

- [Design of Safe Operation Scheme of Charging Station Based on AI Particle Swarm Optimization](#)  
Xiaohui Yu, Kejun Qian and Hui Gao
- [Research on Carbon Accounting Method and Economy of Electric Vehicle Charging Facilities Participating in Carbon Emission Permits Trading](#)  
Weicheng Chen, Yuqing Wang, Shi Tian et al.
- [The rise of electric vehicles—2020 status and future expectations](#)  
Matteo Muratori, Marcus Alexander, Doug Arent et al.

### ECS Toyota Young Investigator Fellowship



For young professionals and scholars pursuing research in batteries, fuel cells and hydrogen, and future sustainable technologies.

At least one \$50,000 fellowship is available annually.  
More than \$1.4 million awarded since 2015!



Application deadline: January 31, 2023

**Learn more. Apply today!**

# Research on data system framework and key technologies of EV charging station maintenance

Jiaqi Liao<sup>1</sup>, Hualiang Fang<sup>1</sup>, Kejun Qian<sup>2</sup>, Chengke Zhou<sup>1,3</sup>, Luyang Dai<sup>1</sup>

<sup>1</sup>School of Electrical Engineering and Automation, Wuhan University, Wuhan 430072, China

<sup>2</sup>Suzhou Power Supply Company, Suzhou 215123, China

<sup>3</sup>School of Engineering and Built Environment, Glasgow Caledonian University, Glasgow, UK

Email: liaojiaqi@whu.edu.cn

**Abstract.** With the increase in the utilization rate of EV (Electric vehicle) charging facilities, the perception of operation status and the intelligent maintenance have become the key technologies of charging station development. A charging station data analysis method based on the two-dimension data framework is proposed according to the power transmission characteristic and data classification. Combined with the frequency and characteristic of fault events as well as the working principle of the charging station, the hardware and software framework based on the data processing and analysis for state evaluation and scientific maintenance planning is designed. Finally, the actual operation and maintenance statistics of the electric bus charging station in Suzhou, China is taken as an example for analysis.

## 1. Introduction

With more importance attached to environmental pollution and energy consumption, the state and local governments have introduced many policies to promote the electric vehicle industry. The operating environment of the charging facilities is mostly located outdoors with the environmental temperature and humidity uncontrollable, which results in the high failure rate. In addition, the lack of operation experience and technology of maintenance personnel result in the low maintenance rate and the long time of the equipment recovery. As the power grid terminal, the perception of the operation status and the scientific and intelligent maintenance have become the practical problems to be solved immediately.

So far, there are some researches on the operation and maintenance management methods of EV charging stations. Reference [1] has designed the charging facility monitoring system through system requirements analysis and functional service requirements, and divided the monitoring system into the system platform level, the supporting service level, and the public service level. Reference [2] proposed a set of embedded charging station power distribution monitoring system to realize data acquisition monitoring, analysis and evaluation, fault alarm and other functions. Reference [3] builds a monitoring system according to the AC and DC charging pile structure of different charging facilities. Reference [4] establishes charging station system model, device information model, communication model, and form a charging station monitoring system modeling program. Reference [5] has designed a system based on PCI bus with multi-DSP to collect the voltage and current of PCC to analyze the operation characteristic. The above researches mainly focus on the development and application of monitoring systems.



Therefore, based on the structure of the EV charging station, combined with the power transmission and operating characteristics of the charging station, considering the frequency and type of each fault event, starting from the working principle of the charging station, the hardware and software framework for state evaluation of the charging station and the scientific maintenance planning is proposed. Finally, the actual operation and maintenance statistics of the electric bus charging station in Suzhou is taken as an example for analysis.

## 2. Charging station structure

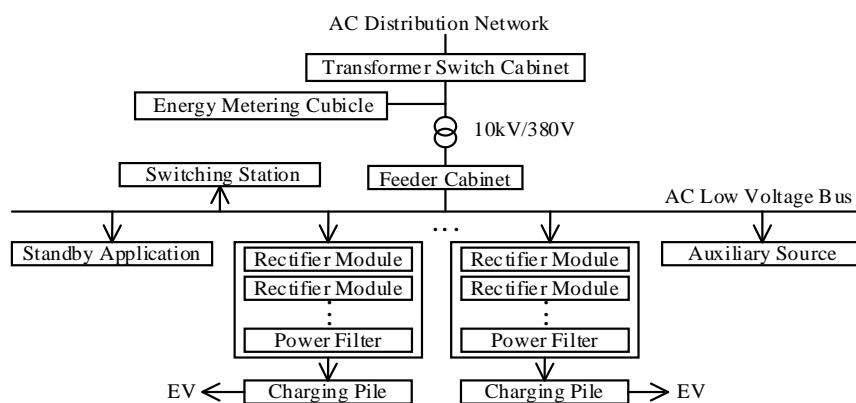

**Figure 1.** Structure of DC charging station

The DC charging station is set up as the city fast-charging station as well as the starting and terminal charging station of the bus, and the direct current is directly supplied to the electric vehicle. The DC charging power is higher and the charging time is relatively short. In addition, the DC charging station is under heavy load, and the rectifier cabinet is also a new type of equipment for the grid. As a result, the structure of the DC charging station is the basis of this study. The structure of DC charging station is shown in figure 1.

The power distribution process of the charging station is like to the traditional power distribution process. The main primary equipment includes transformer switch cabinet, main transformer and feeder cabinet. The secondary equipment includes high-voltage energy metering cubicle, relay protection device and control device. After each transformer, a wire cabinet is arranged, and a single busbar section wiring is arranged in the outlet cabinet, and a sectional switch is arranged between the busbars. Each feeder cabinet in the outlet cabinet distributes the electric energy to the charger in the rectifier cabinet and various auxiliary systems.

The charging cabinet in the rectification chamber is consisted of a plurality of charging modules in parallel according to different capacities and the core device of the charging station. The main body of the charger is connected to the feeder cabinet through a three-phase input contactor. Since a single power charging module is difficult to achieve high-power output and the reliability of the system needs to be improved, a distributed system must be implemented, that is, multiple identical power modules with the same current are connected in parallel. An active filter module is usually installed in the charger to reduce harmonics generated by the charging module that pollute the power grid.

The charging pile is the charging device that the EV user interacts with the power grid. The charging pile is internally provided with a TCU (Terminal Control Unit), a charging monitoring unit, and a charging execution unit. The charging monitoring unit can monitor the voltage, current, temperature of each key node in the charging station, the running status information of each switch device and communication device in the station. The charging execution unit can control the operation of the communication metering device such as the BMS (Battery Management System), the electric energy meter, the TCU, and the switching states of the switching devices in the station, as well as

controlling the related devices according to the data input of the monitoring unit. The TCU can record the working information of the monitoring unit and the execution unit as well as the charging information and cost of the user using the charging pile.

### 3. Maintenance framework and fault events

Different from the traditional substation operation and maintenance method, the electric vehicle load of the charging station is intermittent, which is different from the ordinary continuous load in the power grid. In addition, as the interactive devices that non-professionals operate frequently, there are many potential failures for the charging piles. Besides, the distribution systems and rectification systems for all city fast charging stations are installed outdoors, which causes its operating status greatly affected by the season, weather and man-made.

#### 3.1. Data analysis framework

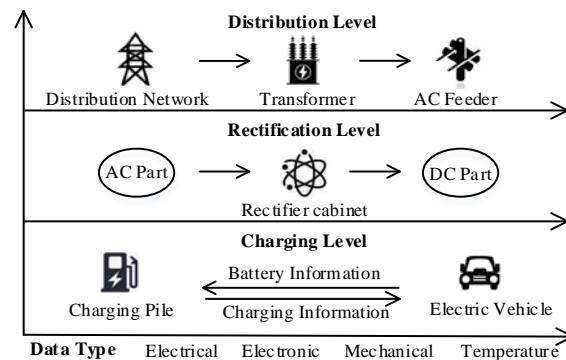

**Figure 2.** Two-dimension data system framework.

Combined with the structure of DC charging station, a two-dimension data analysis framework based on the status evaluation, fault analysis and maintenance are proposed to establish the data system of charging station. The transmission process of electric energy from top to bottom is divided into distribution level, rectification level and charging level. Each level is composed of electrical device, communication equipment, switch and others, which forms the vertical dimension. In addition, a large amount of data is generated while the equipment is running, which is closely related to the operating state of the charging station. According to the type and characteristics of data, it can be divided into electrical data, electronic data, mechanical data, temperature data, etc. The two-dimension data analysis framework is shown in figure 2. At present, the maintenance of electric vehicle charging stations still stay in the traditional stage with manual inspection. Although a large amount of historical operation data has generated, there is no specific data system to store and analyze the data. The main idea of the designed hardware and software is to make full use of historical data and real-time data through the two-dimension data analysis framework to realize the status monitoring, maintenance management and fault prediction of the charging station.

The main idea of the designed hardware and software is to make full use of historical data and real-time data through the two-dimension data analysis framework to realize the status monitoring, maintenance management and fault prediction of the charging station. The characteristic quantity is analyzed separately for each device in each level, and the fault information can be quickly located.

#### 3.2. Fault events analysis

Various types of faults in the charging station are related to the characteristic quantities of the related equipment. For the distribution system level, it is like to the failure event analysis of a traditional substation. The main faults of electrical type include phase loss fault, short circuit fault, open circuit

fault and bus switch status. Electronic faults mainly include state monitoring system faults, remote faults, etc. Main mechanical faults are abnormal wiring, joint damage, etc. The quantities of internal and external environment include three-phase winding temperature and humidity. By the horizontal dimension of the rectification system level, some common fault events can be summarized as shown in table 1.

**Table 1.** Fault events in rectification system level.

	Electrical	Electronic	Mechanical	Environment
AC Part	Undervoltage input, Undervoltage output, Contactor fault	Monitoring com-mnication fault, Measuring fault	Joint damage, Abnormal wiring	High temperature
Rectification	Charging module fault, Air switch trip	Module commu-nication fault	Loose connection, Abnormal wiring	High temperature, High humidity
DC Part	Under current input, Under current output	Measuring fault	Joint damage, Abnormal wiring	High temperature

For the charging system level, the interactive devices such as cables and display screens have various fault events, and there exists failures when the EV is changing information with charging piles as a result of human factors such as user operability and frequent operation. The partial fault events can be summarized as shown in table 2.

**Table 2.** Fault events in charging system level

	Electrical	Electronic	Mechanical	Other
Charging pile	Under current output, Undervoltage output, Charger insulation damage, Abnormal auxiliary power	Monitoring commni-cation fault, BMS communication fault, Abnormal data display, Offline	Cable damage, Card slot damage, Wiring fault, Screen damage	Cable high temperature, Arrester fault
Electric vehicle	Under current input, Battery damage	BMS handshake failure	Charging socket damage	

## 4. Hardware and software framework

### 4.1. Hardware framework design

For the hardware part, it consists of modules such as data input, central processing unit, upper management machine and data storage system, including data acquisition, data transmission and data storage. Firstly, the data is pre-processed through data cleaning, fusion and correction. Secondly, the data is layered and integrated to analyze for the state evaluation and fault diagnosis. In addition, the data platform is expanded by the network or cloud technology. Similarly, if the fault judgment module diagnoses that the equipment of charging station system is running under abnormal condition, the

maintenance decision will be output. The hardware framework design of operation and maintenance system is shown in figure 3.

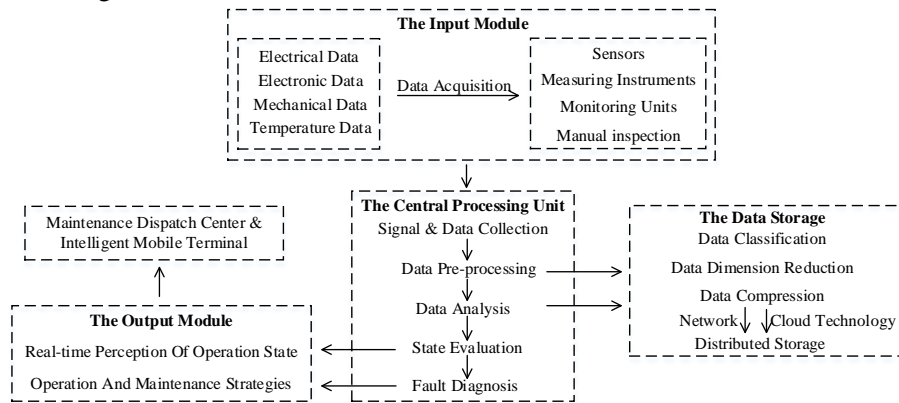

**Figure 3.** Hardware framework design of operation and maintenance system

For the collection of electrical data, the sensors such as voltage and current sensors are directly positioned. The switching data is analyzed by installing the vibration measuring instrument for vibration signal acquisition and the current sensor for signal processing analysis [6]. For communication data, it can be obtained from the process information downloaded from the monitoring board. The mechanical data can be periodically recorded by the manual inspection method. The temperature and humidity sensors can be directly installed for monitoring the internal and external environmental data of the device.

4.2. Software framework design

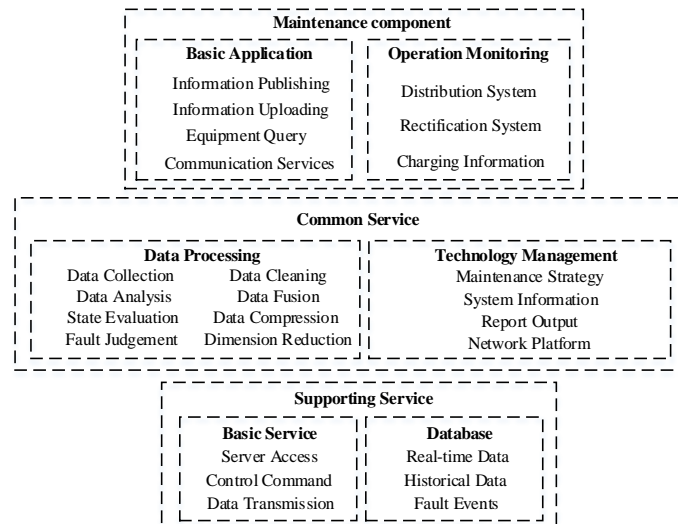

**Figure 4.** Software framework design of operation and maintenance system

For the software part, the state evaluation will perform data analysis on the data uploaded to the central processing unit after acquisition to estimate the status of the charging station and upload the result to the server in real time, so that the operation and maintenance personnel can monitor the status of charging station anytime and anywhere. For the fault analysis, the central processing unit analyzes the key characteristic quantities of the operational data to determine whether it has abnormal

conditions, and quickly infers the type of fault events and locates them, as well as the warnings of potential faults and offline. For the fault event, the historical processing method is called from the event database, and the real-time maintenance strategy is formulated for reference to the operation and maintenance personnel. The improved software design framework of operation and maintenance system is shown in figure 4.

The software is composed of maintenance component level, common service level, and supporting service level. The maintenance component level includes the monitoring information visualization part and the basic application part for the maintenance personnel maintenance company. The operation monitoring includes the distribution system, rectification system and charging information. The common service level includes data processing and technology management. The function of technology management is information visualization generation, which includes maintenance strategy, system information, report output and network platform. The supporting service level includes basic services for software operations and various databases including real-time data, historical data and fault events.

**5. Application analysis**

At present, the fault information of DC charging station can be obtained through the reporting of TCU to the monitoring unit for automatic monitoring and the detecting of the maintenance personnel manually. According to the statistical analysis of the common equipment defects and the common TCU reporting faults of the Suzhou company from January to August 2018, firstly, the frequency of the common equipment defect is shown in figure 5.

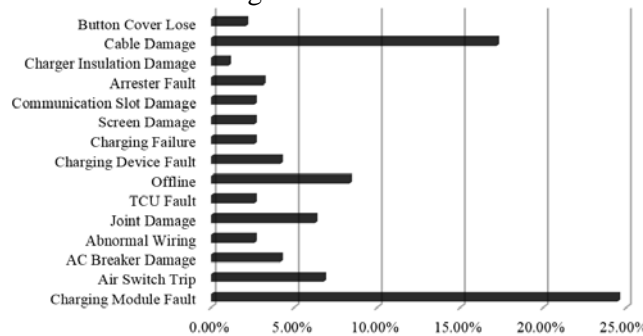

**Figure 5.** Frequency of common equipment defect

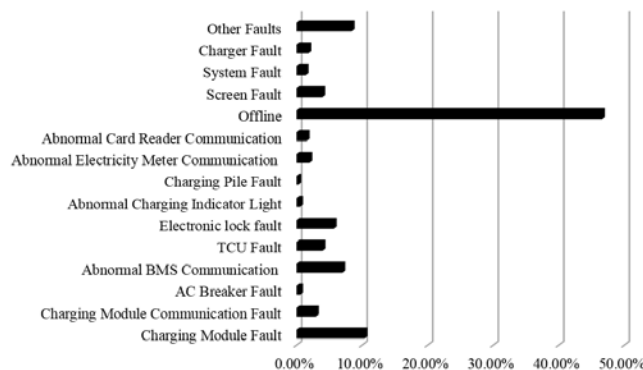

**Figure 6.** Frequency of common faults reported by TCU

It can be inferred that the most frequently occurring faults of the charging station during the current maintenance are charging module fault, cable damage and offline failure. Repairs can be made by



directly replacing the module, replacing the fan unit, and changing the parameter data. The cable damage mainly includes the crack of charger and the repair method is to directly replace the cable. For the offline, the common way to solve the it is to restart the motherboard inside the charging pile. The maintenance framework studied in this paper contains monitoring and analysis methods for existing frequent faults, and forms operation and maintenance processing decisions based on fault characteristics.

The frequency of the common faults reported by TCU is shown in figure 6. For the faults that TCU reports, the offline fault is the most frequent, reaching 75% of the total fault. According to the TCU setting, after the offline fault occurs, the charging pile cannot be recorded, so the charging pile is in a fault state and is suspended. Other faults monitored by the TCU include the auxiliary power supply damage, the motherboard of the monitoring actuator unit damage, program not updated, audio cable damage, etc.

## 6. Conclusion

The research on hardware and software will eventually be popularly applied to the bus charging station that has been put into operation. Through the combination of the research and technology of this paper and the maintenance work of the charging station, it can visually monitor and evaluate the operating status of each charging facility, and make a quick judgment and positioning of the fault.

Subsequent research should consider the faults more comprehensively, and with the development of new energy sources, photovoltaic charging station and energy storage should also be considered. Further, the analysis method and application of artificial intelligences should be combined with the operation and maintenance to solve the issues of charging station and provide EV users great charging services.

## Reference

- [1] M. Zhao, G. Wang, Y. Wang and G. Sun 2011 Design and implementation of monitoring system for electric vehicle charging facilities *Automation of Electric Power System* **35(10)** p 65-69, in Chinese.
- [2] J. Zhang, S. An and D. Gao 2018 Development of power distribution monitoring system for electric vehicle charging station based on Qt *Industrial Instrumentation & Automation* **2018.1** p96-100, in Chinese.
- [3] H. Yan, G. Li, L. Zhao and B. Wu 2009 Design and implementation of monitoring system for electric vehicle charging station *Power System Technology* **33(12)** p15-19, in Chinese
- [4] Y. Hu, Z. Guo, Q. Liu and M. Tang 2013 Modeling scheme of electric vehicle charging station monitoring system based on IEC 61970/61850 *Automation of Electric Power System* **37(2)** p91-96, in Chinese.
- [5] X. Nie, J. Liu, L. Xuan, H. Liang, S. Pu, Q. Wang and N. Zhou 2013 Online monitoring and integrated analysis system for EV charging station *2013 IEEE PES Asia-Pacific Power and Energy Engineering Conference (APPEEC)*, Kowloon, 2013 p1-6.
- [6] Y. Yang, Y. Guan, S. Chen, J. Wang and K. Zhao 2018 Mechanical fault diagnosis method for high voltage circuit breaker based on sound signal *Proceedings of the CSEE* **38(22)** p6730-6737, in Chinese.