

Review of recent research towards power cable life cycle management

Zhou, Chengke; Yi, Huajie; Dong, Xiang

Published in:
IET High Voltage

DOI:
[10.1049/hve.2017.0037](https://doi.org/10.1049/hve.2017.0037)

Publication date:
2017

Document Version
Author accepted manuscript

[Link to publication in ResearchOnline](#)

Citation for published version (Harvard):

Zhou, C, Yi, H & Dong, X 2017, 'Review of recent research towards power cable life cycle management', *IET High Voltage*, vol. 2, no. 3, pp. 179-187. <https://doi.org/10.1049/hve.2017.0037>

General rights

Copyright and moral rights for the publications made accessible in the public portal are retained by the authors and/or other copyright owners and it is a condition of accessing publications that users recognise and abide by the legal requirements associated with these rights.

Take down policy

If you believe that this document breaches copyright please view our takedown policy at <https://edshare.gcu.ac.uk/id/eprint/5179> for details of how to contact us.

Review of Recent Research towards Power Cable Life Cycle Management

Chengke Zhou¹, Huajie Yi^{1*}, Xiang Dong²

¹ School of Engineering and Built Environment, Glasgow Caledonian University, Cowcaddens Road, Glasgow, UK

² China State Grid, Beijing Electric Power Company, Beijing, China

* Huajie.Yi@gcu.ac.uk

Abstract: Power cables are integral to modern urban power transmission and distribution systems. For power cable asset managers worldwide, a major challenge is how to manage effectively the expensive and vast network of cables, many of which are approaching, or have past, their design life. This paper provides an in-depth review of recent research and development in cable failure analysis, condition monitoring and diagnosis, life assessment methods, fault location, and optimisation of maintenance and replacement strategies. These topics are essential to cable life cycle management (LCM), which aims to maximise the operational value of cable assets and is now being implemented in many power utility companies. The review expands on material presented at the 2015 JiCable conference and incorporates other recent publications. The review concludes that the full potential of cable condition monitoring, condition and life assessment has not fully realised. It is proposed that a combination of physics-based life modelling and statistical approaches, giving consideration to practical condition monitoring results and insulation response to in-service stress factors and short term stresses, such as water ingress, mechanical damage and imperfections left from manufacturing and installation processes, will be key to success in improved life cycle management of the vast amount of cable assets around the world.

1. Introduction

Worldwide, electric power transmission and distribution relies on vast and expensive networks of high voltage (HV) and medium-voltage (MV) cables for power delivery. In developing countries, the cable networks are relatively new and still growing rapidly: taking China as an example, the cables laid down over the last 10 years account for more than half of the cable population [1]. Understanding the implications of different strategies for managing these assets is important, e.g. most cable failures are due to third party damages, manufacturing and poor installation problems [2]. In contrast, in developed countries such as in the UK, installation peaked in 1950s and 1960s [3] and a large proportion of the cable assets are approaching or have already past their design life. In this population a higher proportion of age related symptoms or failures have been reported [4].

During power system operation, power cables and cable accessories are subject to electrical, thermal, mechanical, and environmental stresses on a constant basis. These stresses often lead to insulation degradation, together with poor practice in installation and maintenance which results in defects, often cause cable breakdowns [5]. As a result, cable and accessory failure times, like other power systems assets,

obey the “bathtub curve” [6] which can be divided into “burn-in phase”, “the useful life phase” and “the wear-out phase” [7]. Early failures usually result from imperfections introduced during manufacturing processes, defects associated with poor installation practice and third party damage. During the second, useful life, phase failures occur for a variety of reasons, such as third party damage, wear-out of components and environmental stress, *etc.* As time progresses, into the third phase, the bulk dielectric strength degrades and artefacts, due to events such as water ingress and detachments at material interfaces, raise local stress. The net effect of these reactions is referred to as ageing, the rate of which depends on many factors such as voltage, thermal stresses, maintenance, system age, cable system technology, and environment [8].

Planned maintenance and replacement of cable assets based purely on age has un-affordably high cost implications and is unnecessary [9]. As cable assets in different areas do not operate under consistent stress conditions they do not age uniformly, meaning that a good proportion of the assets which are working below defined stress levels can provide service well beyond their design life. Cable asset managers and maintenance engineers therefore face significant challenges when considering how to deal with the increasingly ageing and expensive cable assets [11], i.e. understanding and accurately modelling the ageing processes in cable assets under service conditions, predicting reliability and future failure rates, and identifying appropriate actions for acutely degraded individual assets or components is imperative. Failing to evaluate the ageing status and condition of individual assets will lead to (a) increased operational risk, due to failure of relatively new assets which may have endured adverse working conditions and stresses, and (b) wasteful investment, through premature replacement of those assets which are aged but still in good condition.

In conjunction with improved condition assessment, fast fault location can contribute to improved reliability of important cable assets, as some cable failures are unavoidable and these unexpected failures account for a significant proportion of customer lost minutes [11]. Examples of such events in developed and developing nations are: Long Island, USA, experienced a nine-day electric power outage which affected 17,500 people [12]; Zanzibar suffered a total power blackout from May 21st to June 18th, 2008 due to cable failure and a second outage lasted from December 10th 2009 until March 9th 2010 [13].

After a brief review of the latest development in cable asset life cycle management and new material research, this paper focuses on a review of advances in research related to condition assessment and maintenance strategies for power cable assets during their service years.

2. Cable life cycle management and new insulation materials

2.1. Cable life cycle management

In ISO 14040 [14], life cycle is defined as a set of consecutive and interlinked stages, i.e. raw materials production, manufacturing, transportation, commissioning, operation and end of life decommissioning and/or disposal, of a product system. However, in ISO 55000 [15], which has a focus on “Asset Management (AM)”, life cycle is referred to as the various stages involved in the management of an asset. Asset management, as outlined in ISO 55000, enables the realisation of value from assets. Value realisation, to be achieved through the use of analytical approaches and implementation processes, aims to bring benefits including improved decision making, maximum financial performance, and reduction of risks which should include considerations of economic, social and environmental factors [16]. In the case of power cable assets, the aim of AM or LCM is to minimise the life cycle cost or maximise the value of the cable assets, within the constraints of power system reliability.

2.2. New cable insulation materials

With increasing demand for power and need for greater transmission capacity, high voltage/extra high voltage (HV/EHV) has been increasingly adopted. High voltage direct current (HVDC) and submarine cabling have been implemented, e.g. to interconnect large scale networks, and are being further developed due to a boom in exploitation of off-shore renewable energy [17]. For example, France has implemented four HVDC interconnection submarine links with Great Britain, Ireland and Spain [18]. The increasing transmission distance and voltage level have raised challenges in meeting the insulation requirements, in terms of both system reliability and personnel safety.

Concerns on recycling or disposal of retired cables have contributed to innovation of insulation material and cable manufacturing technology. In contrast to the insulation in cross-linked polyethylene (XLPE) cables, that in Polypropylene (PP) cables can be recycled at the end of its lifetime which is eco-friendly to the environment. However, in order to enhance the mechanical strength of PP, polyolefin elastomer (POE) were introduced by melt blending [19]. In addition, surface modified magnesium oxide (MgO) nano-particles have been introduced into PP/POE blends to suppress the accumulation of space charge [20]. It is noted that the content of MgO in PP/POE blends should not exceed one percent, otherwise the dielectric properties of the nano-composites will decrease due to the agglomeration of the nano-fillers [21]. The new developments in nano-filler insulation systems are mainly aimed at HVDC cables.

As underground cables are prone to damage resulting from poor installation, rodents and human factors, self-healing cables are being developed. Once a cable is damaged, viscoelastic sealant will flow out and seal the damaged point and help prevent moisture ingress [22]. Results of a survey of 600V cables in the USA showed that self-sealing cables had a decreased failure rate.

Because the peroxide by-product generated in chemically crosslinked XLPE was indicated as the cause of partial discharge [23], a cause of cable failures, inorganic fillers, such as calcium carbonate (CaCO_3), were introduced. Although this addition can also improve the dielectric strength and the thermal stability of XLPE, it can also decrease the mechanical properties [24]. The tri-functional fillers, which are characterized by allylic functions, react with radical peroxide during the crosslinking reaction [25]. The combination of fillers and peroxide significantly reduces the peroxide by-product content and provides good crosslinking density values.

Progress has also been made in understanding fault processes in cable conductors. The process of aluminium corrosion in damaged LV cables, due to contact with ground water, has been better understood and validated by Dutch researchers. During the corrosion process, aluminium reacts with water and combines with hydroxide, accompanied by the generation of hydrogen [26]. The rate of removal of aluminium from the core has been tested to evaluate the failure possibility of damaged LV cables. Copper-clad aluminium (CCA) was proposed as an alternative to copper and this material was used as cable conductor in USA. High quality CCA provides lighter weight and lower cost while also giving acceptable mechanical and corrosion resistance properties [27].

3. Failure causes and statistical analysis

3.1 Failure causes and mechanisms

A recent survey of cable failure data carried out by Netherland DNV GL Energy, based on approximately 170 individual cases between 1997 and 2014, [28] indicated that the proportion of joint failures, termination failures and cable body failures was 37%, 32% and 31% respectively. Manufacturing defects and poor workmanship were the major causes of cable failure. However, in China, failure data between 2009 and 2011 [29], and failure data collected from different provinces in 2013 [30, 31] indicated that external damage had been the largest failure factor. The proportion of failure causes related to Medium Voltage (MV, rated at 10 kV and 20kV) distribution cables and High Voltage (HV, rated at 35kV, 110 kV and 220 kV) transmission cables in Chinese installations are shown in Fig. 1.

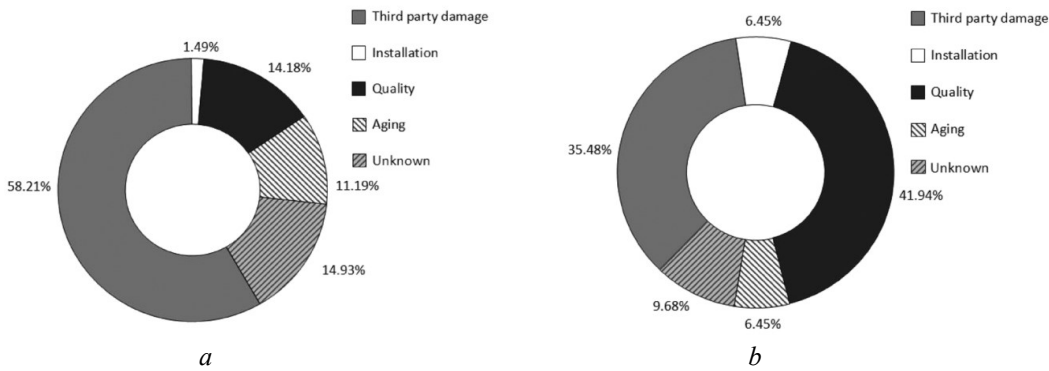

Fig. 1. Distribution of failure causes in China [32]
a Composition of MV cable failures (10kV and 20kV)
b Composition of HV cable failures (35kV, 110kV and 220kV)

Cable accessories, including joints and terminations, need to be installed in the field and connected to the body of the cable. A main cause of failure in cable accessories is due to poor installation quality because of adverse installation conditions and insufficiently experienced jointers. Poor installation usually results in early failures in cable accessories, e.g. Fig. 2 (a) [33]. Poor manufacture of cable body or accessories has also been found to be a reason for failure, due to deficiencies in pre-qualification tests and type tests in previous years, as shown in Fig. 2 (b) [34]. Ageing factors, i.e. thermal, electrical, mechanical and environmental stresses, can act singly or synergistically on cable insulation defects. The applied stresses and factors of influence, such as PD and water trees, which affect insulation ageing can be summarised, as in Fig. 3.

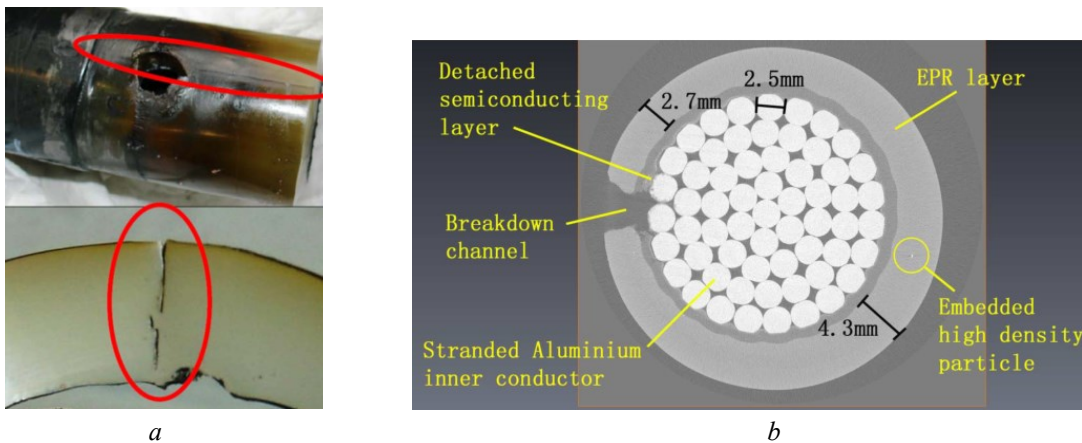

Fig. 2. Cable fault mechanisms, results and consequences
a Early failure caused by poor workmanship (use of inappropriate tools: knife) [33]
b Poor design (core eccentricity and embedded metal particles) resulted in accelerated ageing [34]

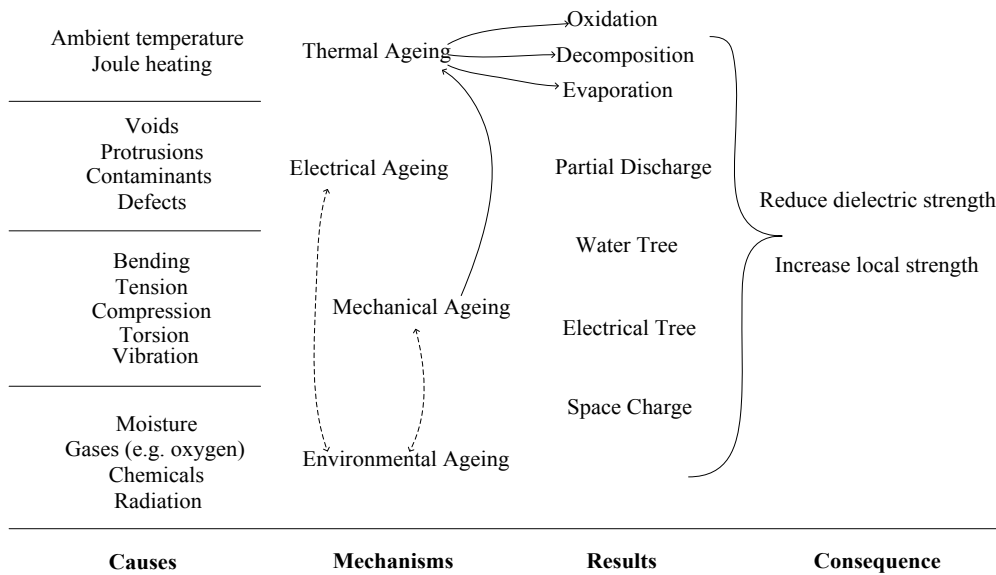

Fig. 3. Ageing causes, mechanisms, results and consequences [35, 36]

The causes of ageing, such as electrical and thermal stresses, and phenomena of ageing, including electrical trees, water trees and PD have been widely researched. However, it has been shown that, under a certain stress threshold, cable insulation may not demonstrate signs of “age” with time [37]. Many paper-insulated-lead-covered (PILC) cable circuits installed in the 1920s, and which are therefore well past their design life, do not yet show signs of imminent failure [32]. It is also recognised that, although many modern XLPE cables are expected to last or service well beyond the 40 year design life under normal circumstances [38], in situations where water/moisture is present, those designs without special protection have a life expectancy of only 15-25 years [39]. Chinese experience shows that cables which are immersed in liquid, due to environmental conditions, have an accelerated failure rate. In addition, utility experience indicates that those circuits which are subjected to frequent switching actions suffer higher failure rate. Furthermore, where cable circuits experience drastic temperature changes, i.e. 40°C in summer and below 0°C in winter, higher failure rates are reported and most of the failures occurred in the summer and autumn [40].

3.2 Statistical analysis of failure data

In cases of age related failures, efforts have been made in using statistical tools for analysis of causes of early failures and for failure rate prediction [41, 42]. The former is important in taking the best decision during the procurement and installation, whilst the latter helps to optimise maintenance and replacement programs.

In [32] a semi-parameter Cox proportional hazard model (PHM) was developed to identify the causes which most significantly contributed to cable failures. Based on the preliminary investigation of

failure factors on 10kV medium voltage (MV) cables and 110kV and 220kV high voltage (HV) cables, a set of time-independent covariates were selected and applied to Hypothesis Test. With a suitable sample size and removal of outlier data, the results demonstrated that, ignoring third-party damage, cable infant mortalities were related to cable installation methods and cable length. The application of Multiple Corresponding Analysis (MCA), which is reported to be capable of analysing the failure behaviour of a diverse population of cables, to cable failure was presented in [43]: according to the Mahalanobis Distance (MD), the performance score of each category (e.g. different voltage levels) in each cable variable (e.g. voltage, length, core cross-section, *etc.*) was calculated to evaluate its failure rate. The MDs which are close to the mean point have high failure tendency or high influence on failure. These were then combined using a clustering technique and the cable category with the highest failure rate was determined and, finally, using the Power Law Non-Homogenous Poisson Process (NHPP) model, the failure trend of each clustering group was obtained.

Despite the differences in failure mechanisms, there are signals and indicators which can advise an asset manager of deterioration in insulation. Condition assessment and failure prediction are important for cable asset managers to arrange appropriate maintenance and replacement programs. The following section will deal with condition monitoring technique research.

4. Cable condition monitoring techniques

Failure of cables is generally preceded by a degradation phase which may last several years. The key to improved assessment of cable integrity and life expectancy therefore lies in the identification and characterisation of prevalent degradation, and its rate of progress from which, in turn, accurate projections of time to failure can be made.

4.1. Partial discharge (PD)

It is widely recognised that the degradation phase, irrespective of the causative mechanism, results in small discharges being generated at the site(s) of degradation. These electric discharges are generally referred to as partial discharges (PD). Since these discharges result from prevalent degradation, their characteristics (magnitude, pulse shape, repetition rate, *etc.*) are influenced by the degradation. In turn, therefore, their detection and characterisation can provide information on the location, nature, form and extent of degradation. To date, the majority of cable condition monitoring research has been based on partial discharge (PD). With the progress in development of PD sensors, data communication, data acquisition and data storage capabilities for both on-line and off-line applications, more accurate and detailed PD observation has become available.

Online PD monitoring or in-service PD measurements in cables are usually implemented using high frequency current transformers (HFCT) clamped around parts of the cable network. Ultra-high frequency (UHF) sensors and acoustic sensors have been used to detect PD signals at cable joints and terminations: UHF sensors can effectively filter any corona discharge signals [44]. Alternatively, new fibre-acoustic sensors which are immune to electromagnetic interference, Fluorescent Polymer Optical Fibres (F-POF), can also allow accurate PD observation [45]. F-POF is made of transparent silicone elastomers which can withstand various stresses within HV/EHV cables. The application of the new F-POF sensors has been validated through laboratory tests and, although it is useful on HVDC cable systems, their effectiveness on practical application to AC cables is still unknown.

Very Low Frequency (VLF) investigation has been popular in off-line testing because it requires a smaller power supply and can reduce the test voltage level required for on-site testing [46]. PD characteristics under VLF conditions have been studied variously by researchers. For PD recognition and fault type classification Phase Resolved PD Patterns (PRPD) has been widely adopted. Under VLF conditions, although the PD inception voltage (PDIV) and extinction voltage (PDEV) are both slightly higher in comparison to those under 50Hz [47], the PD patterns do not differ in qualitative terms [48]. The combination of VLF $\tan\delta$ (phase angle between voltage and current) and VLF PD measurement can give additional information on the cable's insulation condition [49]. Combined PD detection after cable installation is recommended in [50], where PD measurements, included PDIV and PD magnitude, were taken into consideration to evaluate the workmanship of newly installed cable joints. Although VLF PD measurement has the advantage of reducing test voltage level, any cable to be investigated must be removed from service as the method cannot be applied under operational condition.

As noise is an inherent problem during PD measurements taken while cables are in-service, successful diagnosis and criticality analysis of PD during on-line monitoring depend very much on the effectiveness of the denoising techniques and recognition of PD patterns. Based on improvements in software and hardware platforms, many researchers have reported on data denoising [51], pattern recognition [52] and criticality diagnostics [53]. Knowledge of PD propagation and attenuation in cables were developed by, among others, Sheng [51]. In this work, the difference between an original PD pulse and the recorded pulse, which had been attenuated during the propagation through the cable and affected by monitoring devices, i.e. HFCT and High-pass filter (HPF), was studied. Based on the transfer function of the cable and the frequency responses of the HFCT and the HPF, analyses verified by laboratory experiments and on-site measurements showed that both the rise time and the pulse width of a PD pulse increase monotonically as it propagates along a cable.

In practical situations, High Voltage cables which are over 1.2 kilometres long are usually cross-bonded (CB), as shown in Fig.4. Cross-bonding of the cable sheaths solves issues relating to induced and circulating currents but makes PD location more difficult, because of the coupling effects between the centre conductor and cable sheath. Based on the previously developed cable transfer function, [54], the coupling effect within such cable systems was quantitatively studied. By comparing the polarity and magnitude of a pulse detected by HFCTs among phases A, B and C at same CB link-box, as shown in Fig. 4, a set of knowledge rules for locating a PD pulse and the cable section containing the PD source were developed.

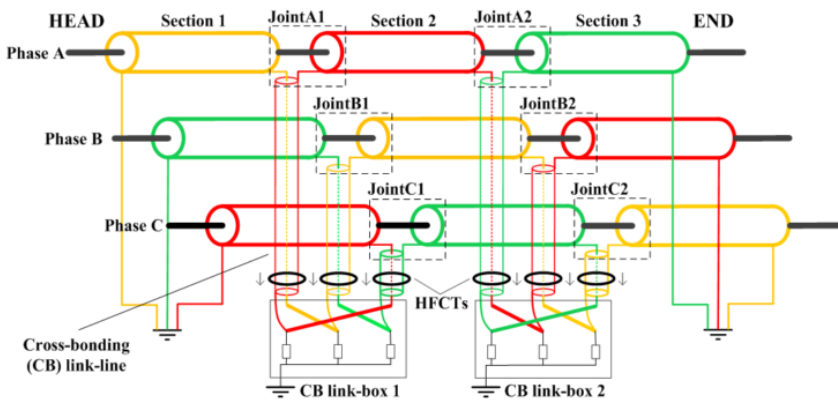

Fig. 4 Model of CB HV cables

As indicated previously, noise is an issue for PD analysis in on-line measurements. In comparison with the PD test based on the IEC 60270 system, the signal to noise ratio (SNR) of commercial HFCT methods is much lower [55]. As a result, separating a PD signal from noisy raw data, which includes white noise and coupled in radio signals, is challenging. An automatic, Synchronous Detection and Multi-information Fusion (SDMF) signal identification method, capable of identifying and separating PD and repetitive pulsed interference, such as that produced by motor control circuitry, was proposed by Peng X. [56]. Other research developed a method based on Rough Set (RS) theory and pattern recognition methods, it was found that this can reject interference signals and recognise PD signals from different sources efficiently [57].

4.2. Dielectric loss (DL)

While PD detection indicates the presence of localised faults, dielectric loss (DL), also named as dissipation factor and $\tan\delta$, reflects the integral degradation of cable insulation. The measurement of DL is usually taken off-line and using VLF equipment, because it requires a smaller power supply and because of the greater leakage current compared with that under power frequency conditions. However, for the

safety of grid operators, VLF voltages cannot be applied in some situations, e.g. nuclear power plants, and therefore the accuracy and resolution of current sensors used in 50Hz-DL measurement needs to be high enough to detect the low level of leakage current. While some international standards have given the criteria of VLF-tan δ [58, 59], as shown in the Table 1 and Table 2, there is still a lack of agreement in the criteria of tan δ under power frequency. DL measurements, which can be applied to various frequencies, are able to reflect integral degradation of cable insulation, but local defects are easily ignored when using the existing DL methods.

Table 1 Mean* Tan δ (VLF-TD at 0.1Hz) [58]

Condition	PE,XLPE, and TRXPPE	EPR	PILC
No Action Required	$< 4 \times 10^{-3}$	$< 35 \times 10^{-3}$	$< 85 \times 10^{-3}$
Further Study Advised	$4 \text{ to } 50 \times 10^{-3}$	$35 \text{ to } 120 \times 10^{-3}$	$85 \text{ to } 200 \times 10^{-3}$
Action Required	$> 50 \times 10^{-3}$	$> 120 \times 10^{-3}$	$> 200 \times 10^{-3}$

* at U_0 , at least 6 single TD measurement should be measured and then the mean value of TD should be calculated.

Table 2 0.1 Hz Tan δ of XLPE [59]

Tan δ at $2 U_0$	Different of Tan δ (Tan δ $2U_0$ - Tan δ U_0)	Assessment
$< 1.2 \times 10^{-3}$	$< 0.6 \times 10^{-3}$	Good
$\geq 1.2 \times 10^{-3}$	$\geq 0.6 \times 10^{-3}$	Aged
$\geq 2.2 \times 10^{-3}$	$\geq 1.0 \times 10^{-3}$	Highly Degraded

The crossing-bonding of the metal sheath for long distance XLPE cables results in circulating currents due to unbalanced section lengths or unbalanced load among the three phases. In [60], the total value of leakage current superimposed by circulating currents was monitored by current sensors and a Leakage Current Separation Method (LCSM) with low error rate ($< 4\%$) was developed. Based on the method applied, comparison of the three-phase leakage currents, relative changes of DL can reveal the relative difference in ageing among the three phases. The method can offset environmental interference and intrinsic measurement errors of current sensors because many sources of errors cancel each other out when only relative changes among the three phases are considered.

For multilayer materials, e.g. multilayer joints and terminations, recent research showed that tan δ value was not a direct function of frequency because of the phase shift of both resistive current and capacitive current. The phase shift at low frequency, below 10Hz, is due to charge accumulation at interfaces of different layers as a result of the different dielectric values [61, 62].

Korea Electric Power Corporation (KEPCO) proposed a three-dimensional assessment criterion of VLF $\tan\delta$ based on IEEE Std. 400.2-2001 [63]. The three dimensions in the proposed method are normalized $\tan\delta$ (DT), normalized Delta $\tan\delta$ (DTD) and a new factor defined as normalized Skirt. While the factor DTD indicates the voltage stability of measured VLF $\tan\delta$, the normalized Skirt reflects the time stability. Skirt factor was first formulated as the difference between the maximum and minimum value of $\tan\delta$, but cable termination effects and measuring errors cannot be described by Skirt. Therefore, a new formula of Skirt with a complementary variable κ was developed. With the introduction of this version of Skirt, the accuracy of VLF $\tan\delta$ was improved. This assessment method can indicate the degree of integral degradation of cables by DT and DTD, as well as can reflect local defects.

4.3. Insulation resistance (IR) measurement

Insulation resistance can most directly reflect on cable condition. Insulation resistance measurement is a DC diagnostic test but according to IEEE Std 43 [64], it needs temperature correction. Tamus et al. [65] proposed that the use of the logarithm of the initial slopes of the decay voltage and return voltage should be chosen when applying temperature correction factors. Compared with the standard, the results showed significant lower value of activation energy, which means that the insulation resistance value calculated based on the standard [64] can be higher than the actual value and may result in oversizing the cable insulation.

Existing insulation resistance measurement methods apply DC voltage to insulation layers when cable circuits are off-line, however, the injection of DC current is not allowed in many situations, e.g. nuclear power generating stations. Novel in-service IR measurement under power frequency condition, if developed, will have huge potential in industry.

4.4. Space charge

Any space charge which accumulates in the cable dielectric leads to distortion of local electric field and this, in turn, accelerates cable ageing and premature failures [66]. The monitoring of space charge accumulation has been carried out by the Pulsed-Electro-Acoustic (PEA) technique during and after prequalification tests, based on CIGRE TB 496 [67, 68]. Results confirm that the accumulation of space charge distorts the electric field significantly and accelerates the ageing of cable insulation [69]. In order to study synergetic effects of stresses, such as temperature gradients and electric fields, the Thermal Step Method (TSM) has been developed to measure the space charge on full size HVDC cables [66]. By measuring the thermal step current on a full size cable with an average electric field applied, the space

charge distribution can be determined: an outer cooling technique is used to maintain the temperature at each thermal step.

The relationship between space charge and breakdown stress was studied, based on simulations, in [70]. It was reported that, under 50Hz excitation, the breakdown strength increased as the voltage ramp rate increased and the sample thickness decreased: the results were fitted and predicted by the Power law with negative exponential index. An early investigation of the simulation and experimental analysis of space charge profiles under 50-1000Hz AC voltage was developed by S. Li [71]. In contrast to the space charge dependent breakdown characteristics under DC conditions, results showed that AC breakdown initialized in the vicinity of the electrode, rather than in the middle of bulk. It was also found that the AC breakdown strength decreased with increased frequency due to the electric field distortion.

In summary, full understanding of space charge dependent breakdown under AC voltage with various frequencies has not been achieved, and the resolution of PEA system is not yet sufficient to detect space charge distribution on small scale, e.g. within 0-2 μm near electrodes.

5. Fault location

Fault location methods are generally off-line and based on time of arrival of PD signals, incident and reflected, associated with a fault. Compared with underground cables, fault location in submarine cables is more difficult to accomplish: repair vessels and experienced crews are required for testing, diagnosing and repairing [72].

Normally the classical fault location method, based on off-line Time Domain Reflectometry (TDR), is applied after a fault event. This method needs the injection of artificial impulse and the cable length should be known [73]. The method is strongly dependent on the fault type and the system's earthing method. An on-line TDR method of detecting cable breakdown, developed by Schierig [73], locates a fault during the fault event by detecting the "signal" generated by the breakdown itself. An advantage of this on-line method is that it does not need the reflection from the far end of the cable, which in turn increases the maximum cable length that the method will operate on. The TDR signals were measured on both cable ends and the location accuracy depended on the exact knowledge of cable parameters and on the accuracy of the synchronisation of the clocks at the cable ends.

Due to the high cost and low accuracy of traditional TDR fault location method when applied to offshore wind farms, the Distributed Acoustical Sensing (DAS) technique was developed [74]. The implementation of this method relies upon the fibre-optic cable which is within the cable structure. In this method, highly coherent laser light is sent into fibre-optic cable and the response of the system's sensor to the acoustic impulse produced at the fault location locates the site of the impulse signal [75].

Smart Cable Guard (SCG) used in Netherland was reported as accurate and effective for on-line fault location in medium voltage (MV) cables [76]. There were two versions of SCG: SCG Defect Locator (SCG-DL), usually those generating partial discharges, and SCG Fault Locator (SCG-FL), which locates faults resulting from a breakdown or a failure. The core construction of the SCG includes two inductive sensors which are used to detect the electromagnetic waves originated from a weak spot or a fault position. Because of the attenuation of wave amplitude and the requirement of high accuracy, the full range of cable lengths is stated as up to 12km. Instead of measuring 50Hz short circuit currents, SCG-FL detects the first slope of the travelling wave from the fault, so that the SCG-FL system is independent of network grounding [77].

In 2009 a fault location system, called Simulation and Location (SimLoc) [78], is a data acquisition system based on a series of simulations with different fault positions was developed. By comparing measurement data with the results of several simulations, the parameters of the best match simulation are used to locate the fault. However, this method showed a low success rate, especially when it applied to long cables with many branch lines. To improve accuracy, a new pinpoint tool, named Confirmation of Location (CoLoc), was developed. The CoLoc tool uses an electromagnetic impulse detector to measure the impulse source current caused by breakdown and to analyse the resonance oscillation [78].

As the repair process of offshore cables are very time-consuming, especially for long and extremely long submarine cables, a related fault location technique was proposed and validated in Italy. TDR and Murray Measuring Bridge Method were combined to locate both low resistance faults and high resistance faults [72].

For cross-bonded HV cables, fault location is more complex due to the multiplicity of current paths. A novel fault diagnostic method based on cable sheath currents was proposed in [79]. In the proposed sheath current monitoring system, the CTs were installed at link boxes and the earthing boxes. By comparing the current detected at cable link boxes and those in adjacent phases the fault type or loop can be determined by pre-established knowledge rules. This method is able to perform fault detection and location in the cross-bonded metal sheath's of HV cable systems.

Generally, fault location methods need artificial pulse signals to be injected into cable circuits, and then compare the incident and reflected waves. Recent efforts at detecting the signals associated with fault events for fault location, using distributed sensors, show good promise and may provide an opportunity for a major technological breakthrough.

6. Cable life assessment and maintenance strategy

Understanding and accurately modelling the ageing processes of cable assets under service conditions, predicting reliability and future failure rate is useful to identify appropriate actions for acutely degraded individual assets or components at the lowest life cycle cost (LCC). In [80, 81] the LCC was calculated in three steps: i) Data processing, historical data such as water tree length, breakdown voltage and failure probability are involved and mathematical relation among them are established and used in next step; ii) Calculation of failure probability and replacement; and iii) Calculation of LCC based on different diagnosis conditions [80] and various diagnosis rules [81].

Great efforts have been made in two approaches, namely a top-down and a bottom-up approach. The top-down approach [82, 83] investigates, statistically, the failure behaviour of a population of assets. The emphasis of this method is on the economic and strategic lifetime assessment and how this behaviour would change with different maintenance and replacement actions. Parameters, such as failure frequency, number of failures in the near future and age of the assets which are most likely to fail, are of most interest. The bottom-up approach captures a group of analytical methods including the investigation of the ageing process, condition of individual components, and numerical simulations based on accelerated ageing testing, or post-mortem analysis [34, 84].

6.1. Statistics based life data and failure rate analysis

Recorded historic failure data can be used to establish a database for further in-depth analysis and to predict the performance and failure rate of cables. When the failure rate exceeds an acceptable level, the cable asset should be replaced proactively.

Weibull Analysis and Crow-Army Material System Analysis Activity (AMSAA) have been applied to predict failure and do trend evaluation [41]. Weibull distribution and Crow-AMSAA, also abbreviated as C-A model, were employed by Yancy Gill [83, 85] to establish a maintenance model of ageing cable. Paul Barringer, P.E. [86] compared the Weibull distribution with the C-A model and concluded that the C-A model worked well with mixed failure modes while the Weibull distribution was a powerful single failure mode tool. In [87], Weibull Analysis were applied to failure data which were segmented into 10 years bins, i.e. 10, 20, 30 and 40 years' old cable bins. From this data a Survivor Curve was evolved from previously four separate Weibull Curves. Taking the advantage of each age bin analysis, the contribution and impact of each ageing models on failures in future years could be estimated.

Tang Z. *et al.* [41] used both Weibull and C-A model to analyse the early failures in cable joints and they made comparisons between the two methods. It was found that the Weibull distribution, which is

based on life data, provides more reliable results in failure behaviour and future failure forecast when the overall population increases rapidly while the C-A model are more straightforward for making predictions of future failure numbers when dealing with incomplete data.

6.2. Physics based individual cable degradation analysis

Statistical models only provide a forecast of the overall failure rate and are unable to determine the individual cable condition. Only with the knowledge of the ageing status of each individual component, can an overall reliability and maintenance/ replacement programme usefully be determined. In [37] Montanari established physics-based life models and ageing equations which originated from laboratory based experimental findings on various types of cable insulation. These models revealed an important finding, i.e. that below a certain threshold, for both electrical and thermal stresses, insulation did not show significant ageing.

According to Montanari and Simoni [37], the reduction in cable life occurs due to thermal and electrical degradation and a strong synergistic interaction between them. The first application in estimation of cable life was proposed by Mazzanti [88, 89] which was based on the cumulative damage law of Miner (also called Miner's rule) [90], however, this was deterministic in nature.

Two lifetime estimation methods for low density polyethylene (LDPE) cables were reported in [91]. The estimation of lifetime was conducted under electric field stresses and moisture condition. Instead of using established combinatorial ageing models, considering thermal, mechanical and electrical stresses, the work considered variation in single stress factors, i.e. electric field frequency or applied voltage. The estimated lifetime model, which had a linear function in logarithmic coordinates, was obtained by curve fitting tools based on accelerating tests under different frequencies. There is always a concern regarding the effectiveness of accelerated ageing test, as the acceleration factors may bias the outcome of the stress application reactions.

Since data related to degradation can provide very useful information about reliability [92], a stochastic electro-thermal degradation model was studied in a research to estimate the reliability and life of cables [40]. In this work degradation under electro-thermal stress was considered to be stochastic in nature, due to differences in seasonal load cycles and in seasonal ambient temperatures. A case study considered two similar 10kV cables: both were directly buried, one was in China and the other was in the UK. The result proved that there is a significant difference in the life of a cable which operates in countries or regions which experience different seasonal load current cycles and soil temperatures. This result has to be treated with caution, as the methodology applies only to analysis of age related insulation degradation and

does not apply to failure due to external factors or to problems resulting from manufacturing quality issues or failures resulting from poor installation practice and external mechanical stresses.

The fundamental science of ageing still needs development in this context, e.g. although there is an increasing body of opinion that space charge plays an important role in AC ageing and failure, no conclusion has been reached on the issue. Further studies will be necessary to validate existing models, as few have been applied to real world situations where cables are subjected to complex, multifactorial stresses. In addition to consideration of local climate condition effects on degradation processes, water quality, e.g. acidity and mineral content, effects on degradation reactions within immersed cables are examples of factors which need ascertained when considering regional variation of insulation life expectancy.

6.3. Cable maintenance and replacement strategy

In [93], a Health Index (HI) tool was developed to assess a cable system's health and to evaluate maintenance strategies. The HI was produced by the following steps: first, necessary attributes, i.e. all the data of a certain asset required for HI method, were obtained through transfer functions based on cable data; in the second step, three types of assessment functions, i.e. Statistical, Condition and Utilization Assessment Function, were applied to each of the cable attributes to produce assessment results; in the third step, after removing uncertainty by Monte Carlo simulations and translating of assessment results by Folding functions, HI indicators were produced to give the remaining lifetime of the asset.

By combining the electro-thermal degradation with power-law NHPP, Sachan et al. [94] proposed a failure prediction method and a methodology for optimising cable maintenance policy for assets with known failure distribution and degradation level. By considering both random and ageing failures, the number of annual failures in future year can be predicted. The maintenance decisions, named as 'keep (K)', 'corrective maintenance (CM)', 'preventive maintenance (PM)' and 'replace (RP)', can be optimised for the assets considered. The case study presented showed a successful application of this method, instead of replacing a cable when its failure rate reaches a pre-defined threshold, taking PM decisions at certain time instants can extend a cable's and reduce life cycle costs.

In the methods used to predict cable failures, most have been based on historical failure data and most of the research has ignored environmental influences on asset life. More efforts need to be made to optimise maintenance strategies, especially given the consideration of the economic, social and environmental impacts, which are key factors according to ISO 55000 [15].

7. Discussion and Conclusions

This paper mainly reviews recent advances in research and development towards cable life cycle management, including cable failure analysis, condition monitoring and diagnosis, fault location techniques, and cable life assessment methods. Major conclusions of the paper and possible future research opportunities are as follows:

- Great opportunities have arisen in developing new insulation materials which are long-lasting and eco-friendly, particularly in terms of disposal at the end of cable service life.
- In respect of failure data analysis, despite the differences in failure mechanisms, condition assessment and failure prediction are important for cable asset managers, allowing them to arrange appropriate maintenance and replacement programs. Novel techniques which allow identification of failure causes will help to improve cable design, manufacturing processes, procurement decisions, installation practices, and targeted condition monitoring campaigns.
- To date, the full potential benefits of cable condition and diagnostic technologies have not been realised. One reason is that, even in well controlled lab experiments, there is considerable scatter, or variability, in insulation testing results. In addition, diagnostic testing is expensive and time consuming and, in most cases, the cable system segment to be tested has to be switched out of service. The lack of accuracy in some analyses may also result in ambiguity regarding the location of signal sources within a cable network. In addition, it is important to carry out further industrially based research to correlate condition monitoring results with a cable's actual condition and remaining life. Artificial intelligence and data mining techniques may hold the key in this regard.
- Fast and effective cable fault location is essential to power system operators, as this reduces economic losses and the social impacts which may result from a prolonged power outage. Existing fault location methods are usually based on TDR theory using injected pulses. There is a potential to further develop on-line monitoring approaches using distributed sensors to detect signals associated with fault events.
- Failure prediction, or life assessment, is another aspect of cable monitoring which can be used to enhance the system reliability. The Top-down, statistical approach, only provides an overall view of the failures and reliability in the past. It treats the population under analysis as a black-box, and does not identify the condition and the actions required for individual assets. Currently there is a lack of knowledge in relation to dealing with condition monitoring data in the existing models. Utility failure data may indicate faults which led to an immediate

power outage but may not provide sufficient detail to allow comparison with defects identified through condition monitoring. Little information is known of the relationship between the stress conditions in a cable and the time for a defect to develop into a full failure. Identifying appropriate datasets, analysing small data sets and censored and/or incomplete data to provide useful relationships is another challenge to be met. Consequently, a novel approach is required to identify the main influencing factors, such as electrical current loading and frequency of switching activities, which can alter the rate of ageing or initiate alternative ageing mechanisms.

- A combination of a physics-based life model and a statistical approach, giving consideration to in-service stress factors and condition monitoring results of the impact of electrical surges, water ingress, mechanical damage and imperfections left from manufacturing and installation processes, will be key to success in improved life cycle management of the massive number of cable assets around the world.

8. References

- [1] Wang M.: 'State Grid Corporation of China's Yearbook 2011'. (China: China Electric Power Press, 2012), pp. 566
- [2] Li H., Zhou Z., and Chen P.: 'Fault analysis for 110 kV and the above HV cross-linking cable system', *Electrical Equipment*, 2004, (8), pp. 9-13
- [3] Walton C. and MacKinlay R.: 'PD monitoring—A critical tool for condition-based assessments', *Transmission and Distribution World*. 2003, 55, (12), pp. 38–46
- [4] Zhou C., Michel M., Hepburn D. et al.: 'On-line partial discharge monitoring in medium voltage underground cables', *IET Science, Measurement & Technology*, 2009, 3, (5), pp. 354-363, doi:10.1049/iet-smt.2008.0100
- [5] Duan X., Tang M., Lin F, et al.: 'Analysis on breakdown of main insulation on middle joint of 220 kV power cable'. *High Voltage Apparatus*, 2009, 45, (6), pp. 142–144, doi:10.13296/j.1001-1609.hva.2009.06.027
- [6] Klutke G., Kiessler P. and Wortman M.: 'A critical look at the bathtub curve', *IEEE Transactions on Reliability*, 2003, 52, (1), pp. 125-129, doi:10.1109/TR.2002.804492
- [7] Luo J., Qiu Y., and Yang L.: 'Operation fault analysis of CLPE power cable above 10 kV', *High Voltage Engineering*, 2003, 29, (6), pp. 14-16, doi: 10.13336/j.1003-6520.hve.2003.06.007
- [8] Begovic M.: 'Cable asset management using failure forecasting and statistical assessment of diagnostic testing', <http://www.wseas.us/conferences/2007/france/mmactee/Plenary4.htm>, accessed 13 October 2007
- [9] Huo X., Pi H., Qiu Q., et al.: 'Condition Evaluation for 10 kV Cables of Shenzhen Bureau Based on CIGRE TB 358', 2016 International Conference on Condition Monitoring and Diagnosis (CMD), Xi'an, China, 25-28 September 2016, pp. 631-634, doi:10.1109/CMD.2016.7757901

- [10] Lanz B. and Broussard B.: 'Application of medium voltage cable predictive diagnostics', Conference Record of 2008 54th Annual Pulp and Paper Industry Technical Conference, Seattle, WA, 2008, pp. 155-163, doi:10.1109/PAPCON.2008.4585805
- [11] Bakker M., Vreeburg J., Rietveld L., et al.: 'Reducing Customer Minutes Lost by Anomaly Detection?', 14th Water Distribution Systems Analysis Conference, Adelaide, Australia, 24-27 September 2012, pp. 913-927
- [12] Stein E.: 'The Long Island City Power Outage Settlement: A Case Study in Alternative Dispute Resolution', Pace Environmental Law Review, 2009, 27, (1), 357-376
- [13] Ilskog E.: 'The Zanzibar Blackout - a case study on consequences from an electricity power crisis', 6th Dubrovnik Conference on Sustainable Development of Energy Water and Environment Systems, Dubrovnik, Croatia, 25-26 September 2011, pp. 1-11
- [14] ISO 14040: 'Environmental management - Life cycle assessment - Principles and framework', 2006.
- [15] ISO 55000: 'Asset management Overview, principles and terminology', 2014.
- [16] Houstin A., Denizet I., Deleu F., et al.: 'Life Cycle Assessment Improvement for Medium Voltage Cable for French market', JICABLE'15, 9th International Conference on Insulated Power Cables, Versailles, France, 21-25 June 2015, pp. 1-5
- [17] Zhang J., Xie S., and Wang L.: 'Key technology study on submarine composite cable with long length, three cores and high voltage', JICABLE'15, 9th International Conference on Insulated Power Cables, Versailles, France, 21-25 June 2015, pp. 1-5
- [18] Boudinet N., Charvet J., Dory M., et al.: 'Design studies for French submarine links', JICABLE'15, 9th International Conference on Insulated Power Cables, Versailles, France, 21-25 June 2015, pp. 1-5
- [19] Zhou Y., He J., Hu J., et al.: 'Evaluation of polypropylene/polyolefin elastomer blends for potential recyclable HVDC cable insulation applications', IEEE Transactions on Dielectrics and Electrical Insulation, 2015, 22, (2), pp. 673-681, doi:10.1109/TDEI.2015.7076762
- [20] Dang B., He J., Hu J., et al.: 'Space charge behaviours of PP/PER/ZnO nanocomposites for recyclable HVDC cable', JICABLE'15, 9th International Conference on Insulated Power Cables, Versailles, France, 21-25 June 2015, pp. 1-6
- [21] Zhou Y., He J., Hu J., et al.: 'Eco-friendly nanodielectrics with enhanced thermal and electrical properties for HVDC cable insulation', JICABLE'15, 9th International Conference on Insulated Power Cables, Versailles, France, 21-25 June 2015, pp. 1-5
- [22] Fletcher C., Mcauliffe J., Perkel J., et al.: 'Validating Reliability Improvements of New Cable Designs – A Case Study of 600 V Self Sealing Cables', JICABLE'15, 9th International Conference on Insulated Power Cables, Versailles, France, 21-25 June 2015, pp. 1-4
- [23] Olsson C., Källstrand B., Ma B., et al.: 'Space charge distribution in XLPE plates with non-uniform conductivity', JICABLE'15, 9th International Conference on Insulated Power Cables, Versailles, France, 21-25 June 2015, pp. 1-6
- [24] Essawi S., Nasrat L., Asaad J., et al.: 'Electrical Performance Improvement of Cross-linked Polyethylene Cables using Inorganic Fillers', JICABLE'15, 9th International Conference on Insulated Power Cables, Versailles, France, 21-25 June 2015, pp. 1-4

- [25] Gard J., Denizet I., Mammeri M.: 'Development of a XLPE insulating with low peroxide by-products', JICABLE'15, 9th International Conference on Insulated Power Cables, Versailles, France, 21-25 June 2015, pp. 1-5
- [26] Kruizinga B., Wouters P., Settnis F.: 'Accelerated Aluminum Corrosion upon Water Ingress in Damaged Low', JICABLE'15, 9th International Conference on Insulated Power Cables, Versailles, France, 21-25 June 2015, pp. 1-5
- [27] Bareggi A. Casiraghi F. De Rai L., et al.: 'Copper-clad aluminum as an alternative to copper flexible conductors for electric power cables: opportunities and challenges', JICABLE'15, 9th International Conference on Insulated Power Cables, Versailles, France, 21-25 June 2015, pp. 1-6
- [28] Van Maanen B., Plet C., Van Der Wielen P., et al.: 'Failures in underground power cables – return of experience', JICABLE'15, 9th International Conference on Insulated Power Cables, Versailles, France, 21-25 June 2015, pp. 1-5
- [29] Wu M., Ouyang B., Li W.: 'Accident Analysis and Dynamic Simulation of Smart Substation', *Electr POWER*, 2013, 46, (5), pp. 66-70, doi:10.16543/j.2095-641x.electric.power.ict.2015.11.019
- [30] Sun G., Zhuang X., Niu H., et al.: 'Statistics and analysis of 10kV distribution cable fault in Pearl River Delta region', *Electrotech Appl.* 2013, (11), pp. 83-85
- [31] Wang Y., Zheng S., Chen L.: 'Statistics and analysis of power cable faults in Jiangxi power grid', *Jiangxi Electr Power*, 2013, 37, (5), pp. 55-57, doi:10.16128/j.cnki.1005-3611.2016.03.025
- [32] Tang Z., Zhou C., Jiang W., et al.: 'Analysis of significant factors on cable failure using the cox proportional hazard model', *IEEE Transaction on Power Delivery*, 2014, 29, (2), pp. 951-957, doi:10.1109/TPWRD.2013.2287025
- [33] Aldhuwaian A.: 'Failure Experience of Medium Voltage Cable Heat Shrink Accessories in Saudi Arabian Transmission Network', JICABLE'15, 9th International Conference on Insulated Power Cables, Versailles, France; 21-25 June 2015, pp. 4-7
- [34] Reid A., Zhou C., Hepburn D., et al.: 'Fault location and diagnosis in a medium voltage EPR power cable', *IEEE Transactions on Dielectrics and Electrical Insulation*, 2013, 20, (1), pp. 10-18, doi:10.1109/TDEI.2013.6451336
- [35] Altamirano J., Andrews T., Begovic M., et al.: 'Diagnostic Testing of Underground Cable Systems (Cable Diagnostic Focused Initiative)' (2010), pp. 38-224
- [36] Densley J.: 'Ageing mechanisms and diagnostics for power cables - an overview', *IEEE Electrical Insulation Magazine*, 2001, 17, (1), pp. 14-22, doi:10.1109/57.901613
- [37] Montanari G. and Simoni L.: 'Aging phenomenology and modelling', *IEEE Transactions on Electrical Insulation*, 1993, 28, (5), pp. 755-776, doi:10.1109/14.237740
- [38] Chmura L., Jin H., Cichecki P., et al.: 'Use of dissipation factor for life consumption assessment and future life modeling of oil-filled high-voltage power cables', *IEEE Electrical Insulation Magazine*, 2012, 28, (1), pp. 27-37, doi:10.1109/MEI.2012.6130529

- [39] Barber K. and Marazzato H.: 'Reliable undergrounding of electricity supply in Asia', Asia Pacific Conference on MV Power Cable technologies, Kuala Lumpur Malaysia, 6-8 September 2005, pp. 1-7
- [40] Sachan S., Wen R., Xiang Y., et al.: 'A Stochastic Electrothermal Degradation Model of Power Cables', High Voltage Engineering, 2015, 41, (4), pp. 1178-1187, doi:10.13336/j.1003-6520.hve.2015.04.015
- [41] Tang Z., Zhou W., Zhao J., et al.: 'Comparison of the Weibull and the Crow-AMSAA Model in Prediction of Early Cable Joint Failures', IEEE Transaction on Power Delivery, 2015, 30, (6), pp. 2410-2418, doi:10.1109/TPWRD.2015.2404926.
- [42] Sachan S. Zhou.C., Bevan G., et al.: 'Failure Prediction of Power Cable Failure Rate Based on Failure History and Operational Conditions', JICABLE'15, 9th International Conference on Insulated Power Cables, Versailles, France, 21-25 June 2015, pp. 380-383
- [43] Sachan S., Zhou C., Wen R., et al.: 'Multiple Correspondence Analysis to Study Failures in a Diverse Population of a Cable', Transactions on Power Delivery, 2016, PP, (99), pp. 1-1, doi:10.1109/TPWRD.2016.2615470
- [44] Koltunowicz W., Badicu L., Hummel R., et al.: 'PD Testing and Monitoring of HV Cable Systems', JICABLE'15, 9th International Conference on Insulated Power Cables, Versailles, France, 21-25 June 2015, pp. 1-6
- [45] Rohwetter P., Siebler D., Eisermann R., et al.: 'Progress in optical PD detection for translucent and transparent HV cable accessories with improved fluorescent optical fibres', JICABLE'15, 9th International Conference on Insulated Power Cables, Versailles, France, 21-25 June 2015, pp. 1-5
- [46] Rao B.: 'Dielectric diagnosis of extruded cable insulation by very low frequency and spectroscopic techniques - A few case studies', JICABLE'15, 9th International Conference on Insulated Power Cables, Versailles, France, 21-25 June 2015, pp. 1-6
- [47] Rethmeier K., Blank R.: 'Partial Discharge Measurements in the Sub-VLF-Range', JICABLE'15, 9th International Conference on Insulated Power Cables, Versailles, France, 21-25 June 2015, pp. 1-6
- [48] Cavallini A., Boyer L., Luton M., et al.: 'Partial Discharge testing of XLPE cables for HVDC : Challenges and opportunities', JICABLE'15, 9th International Conference on Insulated Power Cables, Versailles, France, 21-25 June 2015, pp. 1-6
- [49] Neier T.: 'Combined Application of Diagnostics Tools for MV Underground Cables', JICABLE'15, 9th International Conference on Insulated Power Cables, Versailles, France, 21-25 June 2015, pp. 1-5
- [50] De Vries F., Smit J., Van Slogteren J.: 'Results of 10 years after installation tests combined with PD detection on MV cable systems', JICABLE'15, 9th International Conference on Insulated Power Cables, Versailles, France, 21-25 June 2015, pp. 1-4
- [51] Sheng B., Zhou C., Hepburn D., et al.: 'Partial Discharge Pulse Propagation in Power Cable and Partial Discharge Monitoring System', IEEE Transactions on Dielectrics and Electrical Insulation, 2014, 21, (3), pp. 948-956, doi:10.1109/TDEI.2014.6832236
- [52] Wang B., Zhai G., Wang Y., et al.: 'High voltage XPLE cable partial discharge localization technology based on high frequency signal transmission characteristics', JICABLE'15, 9th International Conference on Insulated Power Cables, Versailles, France, 21-25 June 2015, pp. 1-5

- [53] Gulski E., Smit J., Wester F., et al.: 'Condition assessment of high voltage power cables', 2004 International Conference on Power System Technology, Singapore, 21-24 November 2004, pp. 1661-1666, doi:10.1109/ICPST.2004.1460270
- [54] Sheng B., Zhou W., Yu J., et al.: 'On-line PD detection and localization in cross-bonded HV cable systems', IEEE Transactions on Dielectrics and Electrical Insulation, 2014, 21, (5), pp. 2217-2224, doi:10.1109/TDEI.2014.004446
- [55] IEC 60270: 'High Voltage Test Techniques - Partial Discharge Measurements', 2001
- [56] Peng X., Wen J., Li Z., et al.: 'SDMF based interference rejection and PD interpretation for simulated defects in HV cable diagnostics', IEEE Transactions on Dielectrics and Electrical Insulation, 2017, 24, (1), pp. 83-91, doi:10.1109/TDEI.2016.006002
- [57] Peng X., Wen J., Li Z., et al.: 'Rough set theory applied to pattern recognition of Partial Discharge in noise affected cable data', IEEE Transactions on Dielectrics and Electrical Insulation, 2017, 24, (1), pp. 147-156, doi:10.1109/TDEI.2016.006060
- [58] IEEE 400: 'IEEE Guide for Field Testing and Evaluation of the Insulation of Shielded Power Cable Systems Rated 5 kV and Above', 2012
- [59] IEEE 400.2: 'IEEE Guide for Field Testing of Shielded Power Cable Systems Using Very Low Frequency (VLF)(less than 1 Hz)', 2013
- [60] Yang Y., Hepburn D., Zhou C., et al.: 'On-line Monitoring and Trending Analysis of Dielectric Losses in Cross-bonded High Voltage Cable Systems', JICABLE'15, 9th International Conference on Insulated Power Cables, Versailles, France, 21-25 June 2015, pp. 1-6
- [61] Walker J., Wolmarans A.: 'Electrical stress distribution in cable accessories when testing at different frequencies', 2010 International Conference on High Voltage Engineering and Application, New Orleans, LA, 11-14 October 2010, pp. 152-155, doi:10.1109/ICHVE.2010.5640841
- [62] Joubert T., Walker J.: 'Influence of heat-shrink joints and terminations on Tan δ values of a medium voltage cable installation at very low frequency', JICABLE'15, 9th International Conference on Insulated Power Cables, Versailles, France, 21-25 June 2015, pp. 1-5
- [63] Kim S., Kim S., Cho N., et al.: 'A Numeric Estimation of the Aging Processing of Polymeric MV Cables Applying Three Dimensional Assessment of VLF tan δ ', JICABLE'15, 9th International Conference on Insulated Power Cables, Versailles, France, 21-25 June 2015, pp. 1-8
- [64] IEEE Std 43: 'IEEE Recommended Practice for Testing Insulation Resistance of Electric Machinery', 2013
- [65] Tamus Z., Csányi G., Tomon G.: 'Investigation of temperature dependence of dc diagnostic tests on LV PVC insulated cables', JICABLE'15, 9th International Conference on Insulated Power Cables, Versailles, France, 21-25 June 2015, pp. 1-5
- [66] Boyer L., Mirebeau P., Girard S., et al.: 'Development of an industrial space charge measurement facility for extruded HVDC full scale cables', JICABLE'15, 9th International Conference on Insulated Power Cables, Versailles, France, 21-25 June 2015, pp. 1-5

- [67] Tzimas A., Lucas G., Dyke K., et al.: 'Space charge evolution in composite XLPE HVDC cable insulation during VSC pre-qualification programme', JICABLE'15, 9th International Conference on Insulated Power Cables, Versailles, France, 21-25 June 2015, pp. 1-5
- [68] Katayama T., Yamazaki T., Murata Y., et al.: 'Space Charge Characteristics in DC-XLPE Cable after 400 kV PQ test', JICABLE'15, 9th International Conference on Insulated Power Cables, Versailles, France, 21-25 June 2015, pp. 1-6
- [69] Meziani M., Mekhaldi A., Tegar M., et al.: 'Electric field distribution in polyethylene insulation used in the electric cables affected by water trees in the presence of space charges', JICABLE'15, 9th International Conference on Insulated Power Cables, Versailles, France, 21-25 June 2015, pp. 1-5
- [70] Zhou C., Chen G.: 'Space charge and AC electric breakdown strength in polyethylene', 2015 IEEE Conference on Electrical Insulation and Dielectric Phenomena (CEIDP), Ann Arbor, MI, 18-25 October 2015, pp. 106-109, doi:10.1109/CEIDP.2015.7352027
- [71] Li S., Zhu Y., Min D., et al.: 'Space Charge Modulated Electrical Breakdown', Scientific report, 2016, 6, pp. 1-4, doi:10.1038/srep32588
- [72] Bawart M., Marzinotto M., Mazzanti G.: 'Challenge of Fault Location on Long Submarine Power Cables', JICABLE'15, 9th International Conference on Insulated Power Cables, Versailles, France, 21-25 June 2015, pp. 1-6
- [73] Schierig S., Böhme F., Pietsch R.: 'An alternative approach about fault location on HVAC and HVDC cables during commissioning and operation', JICABLE'15, 9th International Conference on Insulated Power Cables, Versailles, France, 21-25 June 2015, pp. 1-6
- [74] Conway C., Mondanos M.: 'An introduction to fibre optic Intelligent Distributed Acoustic Sensing (iDAS) technology for power industry applications', JICABLE'15, 9th International Conference on Insulated Power Cables, Versailles, France, 21-25 June 2015, pp. 1-6
- [75] Singh K., Minto C., Godfrey A.: 'OptaSense ® Distributed Acoustic Sensing (DAS) Systems for the Power Network', JICABLE'15, 9th International Conference on Insulated Power Cables, Versailles, France, 21-25 June 2015, pp. 1-4
- [76] Wagenaars P., Steennis F., Broersma T., et al.: 'Accurate on-line fault location (full breakdowns) for MV cables with Smart Cable Guard', JICABLE'15, 9th International Conference on Insulated Power Cables, Versailles, France, 21-25 June 2015, pp. 1-5
- [77] Qian Y., Wagenaars P., Harmsen D., et al.: 'Risk on failure, based on PD measurements in actual MV PILC and XLPE power cables', JICABLE'15, 9th International Conference on Insulated Power Cables, Versailles, France, 21-25 June 2015, pp. 1-3
- [78] Reynaud L., Pineau D., Charette D.: 'Prelocating and Pinpointing Faults on Underground Medium Voltage Cables: Review of Hydro-Quebec's Experience', JICABLE'15, 9th International Conference on Insulated Power Cables, Versailles, France, 21-25 June 2015, pp. 1-6
- [79] Dong X., Yang Y., Zhou C., et al.: 'On-line Monitoring and Diagnosis of HV Cable Faults by Sheath System Currents', IEEE Transactions on Power Delivery, 2017, PP, (99), pp. 1-1, doi:10.1109/TPWRD.2017.2665818

- [80] Kato T. and Suzuoki Y.: 'Robustness Assessment of Life-Cycle-Management of CV Cables based on Degradation Diagnosis', 2007 IEEE International Conference on Solid Dielectrics, Winchester, UK, 8-13 July 2007, pp. 192-195, doi:10.1109/ICSD.2007.4290785
- [81] Wu K., Cai W., Gao M., et al.: 'Investigation of Economic Feasibility of Different Rules of Insulation Diagnosis', IEEE Transactions on Dielectrics and Electrical Insulation, 2009, 16, (3), pp. 909-916, doi:10.1109/TDEI.2009.5128534
- [82] MacKinlay R.: 'Managing an aging underground high-voltage cable network', Power Engineering Journal, 1990, 4, (6), pp. 271-277, doi:10.1049/pe:19900054
- [83] Ainscough J. and Forrest I.: 'Predicting medium-voltage underground-distribution cable failures', Proc. IEEE PES-ICC Fall Meeting. Scottsdale, AZ, USA, November 2009, pp. 1-11
- [84] Gill Y.: 'Development of an electrical cable replacement simulation model to aid with the management of aging underground electric cables', IEEE Electrical Insulation Magazine, 2011, 27, (1), pp. 31-37, doi:10.1109/MEI.2011.5699445
- [85] Gill Y.: 'Forecasting underground electric cable faults using the Crow- AMSAA model', Asset Management & Maintenance Journal, 2011, 24, (1), pp. 40-41
- [86] Barringer P.: 'Predict failures: Crow-AMSAA 101 and Weibull 101', International Mechanical Engineering Conference, Kuwait, 5-8 December 2004, pp. 1-14.
- [87] Wald D., Perkel J., Hampton N.: 'Decision Making & Forecasting using the data available to Utilities – Pitfalls , Challenges, and Case Studies of ways forward', JICABLE'15, 9th International Conference on Insulated Power Cables, Versailles, France, 21-25 June 2015, pp. 1-6
- [88] Mazzanti G.: 'The Combination of Electro-thermal Stress, Load Cycling and Thermal Transients and its Effects on the Life of High Voltage ac Cables', IEEE Transactions on Dielectrics and Electrical Insulation, 2009, 16, (4), pp. 1168-1179, doi:10.1109/TDEI.2009.5211872
- [89] Mazzanti G.: 'Effect of the combined electro-thermal stress, load cycling and thermal transients on polymer-insulated high voltage ac cable life', IEEE Power Engineering Society General Meeting, Hilton, San Francisco, USA, 12-16 June 2015, pp. 95-102, doi:10.1109/PES.2005.1489665
- [90] Miner M.: 'Cumulative damage in fatigue', Journal of Applied Mechanics, 1945, 67. A159-A164
- [91] Plopeanu M., V. Notingher P., Stancu C., et al.: 'Underground power cable insulation electrical lifetime estimation methods', UPB Scientific Bulletin, 2013, 75(1), 223-238
- [92] Gorjian N., Ma L., Mittinty M., et al.: 'A review on degradation models in reliability analysis', the 4th World Congress on Engineering Asset Lifecycle Management, Athens, Greece, 28-30 September 2009, pp. 369-384, doi:10.1007/978-0-85729-320-6_42
- [93] Meijer S., Van Der Wielen P., Vermeer M., et al.: 'Underground Power Cable Health Indexing and Risk Management', JICABLE'15, 9th International Conference on Insulated Power Cables, Versailles, France, 21-25 June 2015, pp. 1-6
- [94] Sachan S., Zhou C., Bevan G. et al.: 'Stochastic dynamic programming approach for proactive replacement of power cables', CIRED Workshop 2016, Helsinki, Finland, 14-15 June 2016, pp. 1-4, doi:10.1049/cp.2016.0680

9. Author Biographies



Chengke Zhou received the B.Sc. and M.Sc. degrees in Electrical Engineering from Huazhong University of Science and Technology, Wuhan, China, in 1983 and 1986, respectively, and the Ph.D. degree in Electrical Engineering from The University of Manchester, Manchester, U.K., in 1994. Now, He is a currently Professor in the School of Engineering and Built Environment, Glasgow Caledonian University (GCU), Glasgow, U.K. Prof Zhou has over 30 years research experience in power systems and HV condition monitoring and has published over 40 papers in IET Journal and IEEE Transactions, among the 160 papers he has published in the area. Prof. Zhou is a Chartered Engineer, Fellow of IET and SMIEEE.



Huajie Yi, a PhD student at Glasgow Caledonian University (GCU), Glasgow, U.K., was born in Hubei Province, China, 1993. She received the B.Sc. degree in electrical engineering and automation and M.Sc. degree in electrical engineering from Wuhan University, Wuhan, China, in 2014 and 2016, respectively. Her research interests are cable insulation resistance measurement through dielectric loss and leakage current under AC condition.



Xiang Dong, was born in China. He received the B.Sc. degree from the North China Electrical Power University, China in 2011. He received the Ph.D. degree in Glasgow Caledonian University in 2014. Since then, he worked in China State Grid, Beijing Electric Power Company. His research interests are circulating and leakage current in cable metal sheath and condition monitoring of power cables.

